

Home Theatre Upgrade

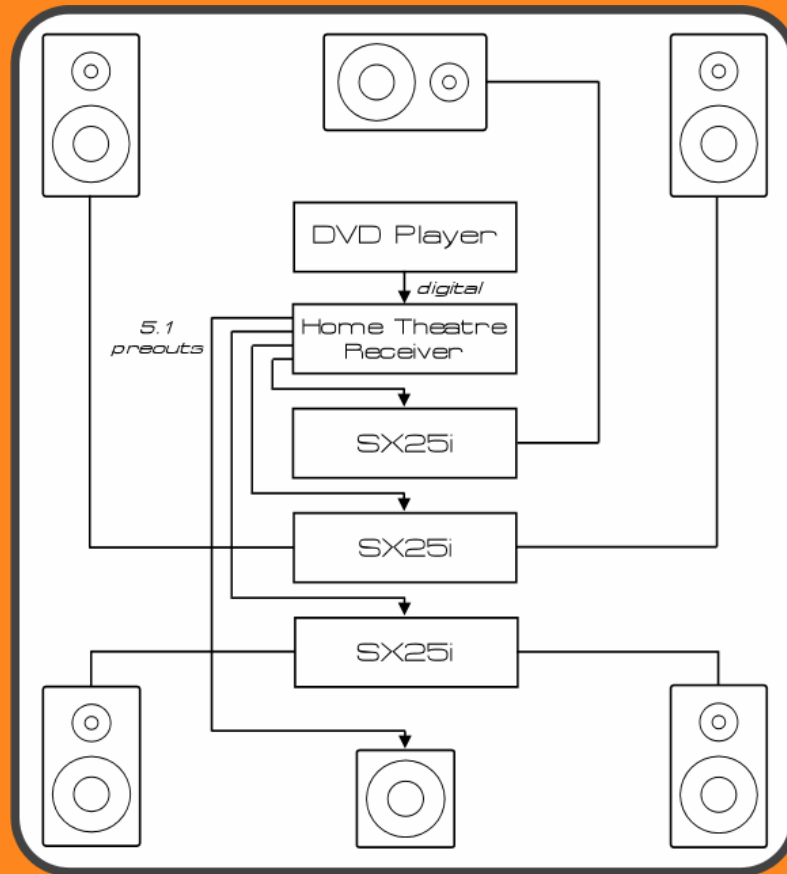

- Improved dynamics
- Greater resolution
- Enhanced channel separation
- Superior noise performance
- Discrete Class AB amplification
- Complementary styling
- Multitude of arrangement options

Home theatre has by far and away been the largest growth area of the audio industry in recent times. Home-theatre-in-a-box, along with reducing prices of entry-level home theatre receivers, has made the home theatre experience accessible to everyone.

Buying into these low-cost home theatre solutions is great, as it gives a leg-up into the technology and the audio-visual experience, but invariably leaves something to be desired.

The single most effective and economic upgrade is to use high-quality external amplifiers instead of the internal amplification stages of the receiver.

Incorporating the Perreaux SX25i Amplifier will bring your home theatre experience to life. By using the 5.1 preamplifier outputs (pre-outs) of your receiver to pass signal to the SX25i amplifiers, the improvement in dynamics and resolution along with less noise will be immediately apparent. Increasing channel-separation, lowering the noise floor and maintaining

authoritative control of the loudspeakers, results in increased spatial perception, greater detail and an extraordinarily lifelike experience.

Although the SX25i is rated at $25W_{RMS}$ (into 8 Ohms), it packs a punch far above its weight. Home theatre receivers are constantly vying for the No.1 spot and hence power ratings are typically bloated and optimistic at best. Rated at a total harmonic distortion of 0.002% @ 1kHz into 8 Ohms, the SX25i is conservatively rated and Martin Bell of technology magazine '>>FFWD' says:

“The baby Perreaux’s 25 watts are delivered with vim and verve – so much so that it makes most 100-watt-plus leviathans sound bloated and ponderous.”

The Class D amplification stages of home-theatre-in-a-box systems do absolutely no favours for the reproduction of sound. Utilising discrete Class A signal stages, along with discrete Class AB output stages, the SX25i maintains signal purity throughout.

Home theatre receivers tend to sound muddled, flat and lifeless, this is primarily due to each amplifier stage (up to 9) sharing the same E-I transformer based power supply. By using three separate SX25i stereo amplifiers where each has their own power supply based around a custom designed toroidal transformer, definitive channel separation results in pinpoint imaging, whilst the low noise floor offers huge dynamics from a black background.

Realise the full potential of your home theatre system without 'upgrading' to the next home-theatre-in-a-box solution. Maintain the signal processing of the receiver and save time and money by simply adding tried and true Perreaux amplification.

Recommended system components:

SX25i Integrated Amplifier

<http://www.perreaux.com/product.php?idp=51>