

Silhouette SX25

25W Power Amplifier



Owners Manual





Perreux Industries Limited makes no warranty for the use of its products, other than those expressly contained in the warranty detailed herein. The Company assumes no responsibility for any errors which may appear in this document, reserves the right to change products or specifications detailed herein at any time without notice, and does not make any commitment to update the information contained herein. No licenses to patents or other intellectual property of Perreux are granted by the Company in connection with the sale of Perreux products, expressly or by implication.

PERREAUX[®] is a registered trademark of Perreux Industries Ltd.

Terms and product names in this document may be trademarks of others.



i

Introducing the Perreaux Silhouette Series

Designed as a range of high quality, yet affordable modules; the 'Silhouette' series will compliment and enhance your existing system.

Drawing on our extensive knowledge gained from more than a quarter of a century of developing highest quality audio products, the 'Silhouette' concentrates our legendary design and build quality into a compact package without sacrificing performance.

The Perreaux 'Silhouette' series provides performance levels never before seen in its class.

Key Features

- Class A signal stages
- Highest quality internal power supply featuring a custom designed, fully shielded toroidal transformer and 13200 μ F of smoothing capacitance
- Optimal internal layout incorporating total separation between channels
- Enhanced audio design featuring highest quality PCB and minimal internal wiring
- Line-out connections
- High current drive
- Compact
- Stylish

The Perreaux "Silhouette" series takes you even closer to the elusive goal of "The Perfect Re-Creation of a Musical Event".

From all of us at Perreaux Industries Limited, thank you for choosing the Perreaux Silhouette Series SX25 Power Amplifier.



ii

Important Safety Instructions

Note: Please read all instructions carefully before attempting to operate your Perreaux "Silhouette" SX25 Power Amplifier.

ALWAYS switch off power to your system before attempting to connect or disconnect cables.

ALWAYS disconnect your system from the mains before attempting to clean your unit.

ALWAYS keep electrical equipment out of reach of children.

ALWAYS unplug sensitive electronic equipment during electrical storms.

NEVER disconnect the mains earth from the system.

NEVER operate the SX25 with the cover removed.

NEVER use any liquid inside the SX25.

NEVER bypass any fuse.

NEVER attempt to repair the SX25. In the event of a problem, please contact your Perreaux dealer.

NEVER expose the SX25 to extremely high or low temperatures.

NEVER operate this product in an explosive atmosphere.



iii

Table of Contents

i	Introducing the Perreux Silhouette Series	2
ii	Important Safety Instructions	3
iii	Table of Contents	4
1	Unpacking and Placement	5
2	Instant Install	6
3	Front Panel Functions	8
4	Rear Panel Functions	9
5	Special Design Philosophies.....	11
6	Special Design Features	13
7	Care and Maintenance	15
8	Warranty Information	16
9	Extended Warranty Registration Form	17
10	Troubleshooting Guide	18
11	Specifications.....	20
12	Physical Dimensions.....	23
13	Contact Details	24



1 Unpacking and Placement

Unpacking Procedure

The SX25 is packaged for maximum protection. To open, sit the box upright and cut the reinforced tape at the top of the box. The product can now be removed.

Pull the foam protecting end-caps off either side of the unit and remove the black material covering.

The SX25 Power amplifier is now unpacked and ready for further installation.

Note: Please retain all packaging material for future transport.

Box Contents

- 1 x SX25 Power amplifier
- 1 x Product manual
- 3 x Performance analysis charts
- 1 x Detachable AC power cord

Placing Your SX25

The SX25 should generally be placed close to your source equipment, thus keeping interconnect cabling between the SX25 and associated components as short as practical. This will reduce the systems susceptibility to radio frequency (RF) interference and the negative effects associated with long cables.

Ventilation Requirements

The SX25 is a convection cooled amplifier. For optimal performance, the unit MUST receive adequate ventilation.

- Please do not cover the product with a cloth or similar.
- Please do not mount the SX25 directly onto carpeted surfaces.

In the event that the SX25 is to be incorporated into custom cabinetry, please refer to the dimensional information provided in the Physical Dimensions section of the manual (Chapter 12).

Note: Please take all necessary steps to ensure that the unit receives adequate ventilation

If you are like us, the first thing you will want to do is to play your favourite piece of music through your new SX25. The following instructions are written to enable you to achieve this as quickly as possible. These are not comprehensive instructions, but are designed to enable you to play music now!

Note: Please take the time to read the SX25 manual thoroughly as it incorporates many features, which will enhance its operation.

Placement

The SX25 is a convection cooled amplifier and best results will be achieved when placed on a solid surface with adequate ventilation. DO NOT place on a carpeted floor or cover the amplifier!

Place the SX25 close or near the source component in order to make as short a connection as possible.

Turn off associated components

This minimises the potential to damage any other components when connecting your SX25 into the system.

Connect source to preamplifier

Connect the audio output from the source component to the input of your preamplifier.

Connect preamplifier to SX25

Connect the audio output from your preamplifier to the inputs at the rear of the SX25. Refer to Chapter 4 for Rear Panel information.

Connect loud speaker cables to SX25

Connect your left and right channel loudspeaker leads to the speaker binding posts at the rear of the amplifier. Refer to Chapter 4 for Rear Panel information.

Note: Make sure the nominal impedance of the loudspeakers is not lower than 2Ω .

Switch on SX25

Caution!

Prior to connecting the AC mains, please check the voltage label on the rear panel to ensure that your unit conforms to the power supply in your area. Never attempt to connect the unit to the incorrect voltage.

Insert the power cord supplied into the rear of the SX25 and into the wall. Switch on the socket at the wall and turn on the power of the SX25 by setting the power switch down.

Switch on preamplifier and source component

Turn on your preamplifier. Power up your source component and start your favourite recording. Slowly increase the preamplifier volume to achieve a comfortable listening level.

CONGRATULATIONS!

Now that you have achieved your first objective, sit back, relax and please read the rest of the manual at your own pace in your favourite armchair whilst sipping a hot cup of coffee. You'll find the whole experience much more pleasurable whilst listening to music.

3

Front Panel Functions



1 Power LED

This blue LED indicates the power status of your SX25 Power Amplifier.

4

Rear Panel Functions

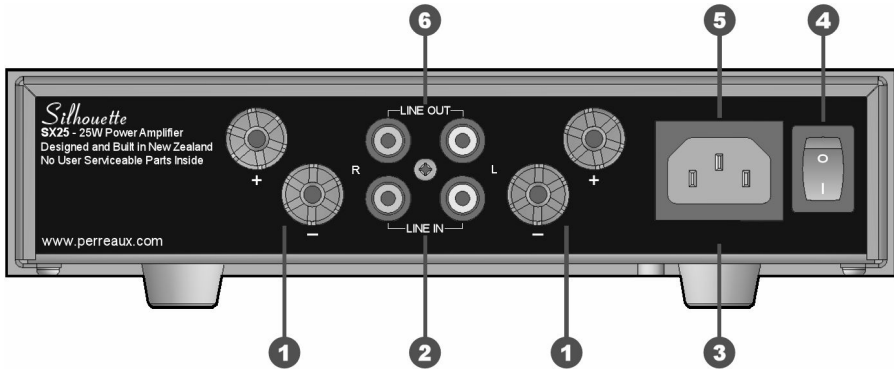

1 Right and Left Speaker Binding Posts

Binding posts are clearly marked and colour coded RED Positive (+) and BLACK Negative (-). This polarity must be observed when connecting loudspeakers, i.e. positive terminal of the SX25 to the positive terminal of the loudspeaker and negative terminal of the SX25 to the negative terminal of the loudspeaker.

Caution!

Never connect the amplifier's output terminals to any device other than a loudspeaker.

Please do not short circuit the amplifier's output terminals.

Never connect the output of one amplifier to the output terminals of another amplifier.

Do not over-tighten the binding posts on your amplifier.

2 Right and Left Line Inputs

Input from source component, accepts a standard unbalanced input (RCA). The left channel connection is on the right when looking from the rear, indicated by white inner ring. For more information on input specifications, please refer to Chapter 11.

3 Serial Number/Voltage Label

The serial number is unique to your SX25. Please record this number and store it in a safe place. For any service related enquiry, please be prepared to quote the product serial number to Perreux personnel or their service representative.

The voltage displayed in this area is the **ONLY** voltage that can be accepted by the unit.

Caution!

Never attempt to connect the unit to the incorrect voltage.

4 On/Off Switch

When operating the switch down, power is applied to the SX25.

5 AC Mains Input

An IEC-standard mains input is provided at the rear of the unit. The AC cord set is removable, allowing it to be upgraded at your will.

6 Right and Left Line Outputs

Line level output, accepts a standard unbalanced input (*RCA*). The left channel connection is on the right when looking from the rear, indicated by white inner ring. For more information on input specifications, please refer to Chapter 11.

Perreux has been designing and manufacturing only the highest quality audio componentry for more than a quarter of a century. Technology has continued to evolve rapidly over that time and our knowledge and application of design, materials and manufacturing techniques has advanced in tandem with this. Today's Perreux range comes closer to fulfilling our shared vision than at any other time in the past.

The SX25 has been developed to meet customer demands for compact higher quality products. Careful attention has been taken throughout the development phase, not to make compromises that would degrade the high quality of reproduction that the unit is capable of delivering.

To follow is a discussion on some of Perreux design philosophies that have been incorporated into the entire range.

Minimalist Design

Leading British architect, John Pawson, writes:

“The Minimum can be defined as the perfection that an object achieves when it is no longer possible to improve it by subtraction. This is the quality that an object has when every component, every detail, and every junction has been reduced or condensed to the essentials. It is the result of the omission of the inessentials”.

Perreux has historically embraced the minimalist ethic from an audio design perspective only. The concept of “less equating to more” has been at the heart of all Perreux audio designs for more than a quarter of a century. Our current product offering takes the minimalist ethic to new levels by totally embracing the concept.

Minimalist Electronics

We wish to maximise the quality of your listening pleasure by keeping the componentry and signal path as uncluttered, short and clean possible. All components in the signal path, even those of the highest quality have an effect on the signal, thereby altering the quality of the reproduction in some way. Our aim is to recreate in its entirety, the original performance by not adding or subtracting anything, irrespective of the source.

Minimalist Aesthetics

Our products appeal to those who seek the ultimate in audio exclusivity, namely the perfect blend of “form and function”.

“Form and function” are both tough masters. We make no excuses for producing some of the most distinctive high-end audio products on the planet. We let “form and function” blend together in perfect harmony. This surely is the essence of true minimalist utilisation.

Minimalism in a Wider Context

John Pawson writes:

“Clearly simplicity has dimensions to it that go beyond the purely aesthetic: it can be seen as the reflection of some innate, inner quality, or the pursuit of philosophical or literary insight into the nature of harmony, reason, and truth”.

6

Special Design Features

Construction

The SX25 is stylish and unobtrusive. The front panel is made from high quality solid 6.0mm (0.2”) thick aluminium extrusion featuring our trademark machined Perreaux logo. These are finished in durable and stylish satin chrome finish electroplate. On/off status is provided via a discreet blue LED inset into the front panel. The chassis and cover are both manufactured from heavy gauge steel. No cover fixing screws are visible. These minimalist styling cues combine seamlessly to allow form and function to blend in harmony and are typical hallmarks of the Perreaux brand.

Circuit Topology

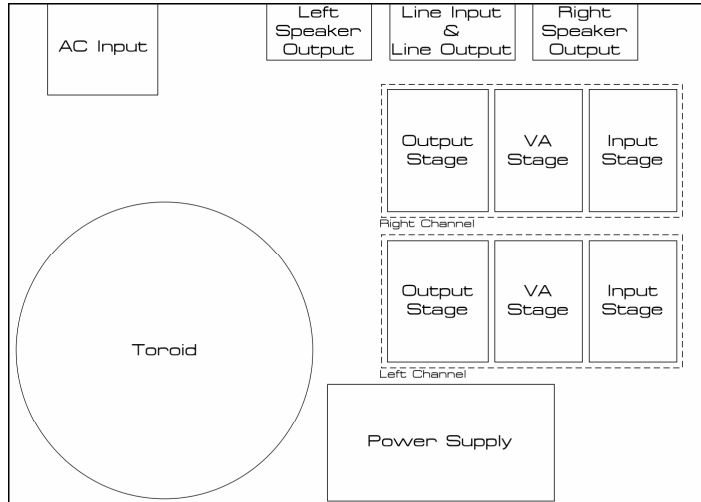

Compact

At 216mm (8.5”) wide x 58mm (2.3”) high x 190mm (7.5”) deep the SX25 is extremely compact.

Unsurpassed Performance

Capable of continuously delivering 25w per channel into an 8Ω load and 35W into 4Ω, the SX25 is powerful for its small stature. When correctly matched to loudspeakers, the SX25 will deliver unsurpassed performance in its class and will effortlessly drive a vast array of smaller loudspeakers with the control and authority that people have come to expect from Perreaux products.

Finest Quality Components Used Throughout The Power Supply

The SX25 features a 98VA toroidally wound mains transformer directly soldered to the PCB, Wima / Elna brand capacitors, highest quality Zobel network and customized internal heat sink solution. The PCB is double-sided and constructed from the highest quality fibreglass base stock featuring 2oz tracks.

Perreaux has specially developed a fully shielded 98VA internal toroidal based power supply. No fewer than six filter capacitors are coupled in parallel providing a total of 13,200uF of power supply smoothing, keeping ripple to a minimum. As a result the power supply is extremely rigid, capable of delivering instantaneous power requirements demanded by musical transients. The result is significantly improved dynamic capabilities.

Simple control functionality

Front panel features on/off LED indication. The rear panel comprises a mains input receptacle, allowing the cord set to be upgraded if desired, mains switch, high quality speaker binding posts, RCA line input and line output.

Single Channel Block Diagram

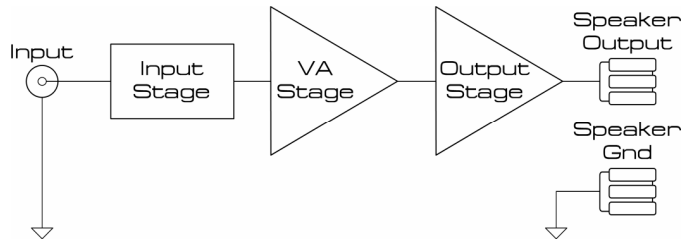

Ultra Short Signal path

Careful attention has been paid to the signal path within the amplifier. It is ultra short, guarded by ground planes where necessary and carefully routed to avoid contamination from power supply and high current bearing sections.

Input Stage

Utilising a stable current source, along with accurate current mirroring circuitry, the input stage of the SX25, in combination with the overall circuit topology, provides precise detail resolution and definitive sonic transparency.

PCB Layout

Special attention has been lavished on the PCB layout. The unit is symmetrical in design with each channel being isolated from the other. The super clean custom designed power supply is physically segregated from the rest of the sensitive electronics.

Signal Ground

Special attention has been paid to ground planes to maintain sonic purity. All signal grounding is optimised to provide a platform for a black background and increased dynamic range.

Note:	<p>Please switch the unit off and remove the cord set from the rear of the Amplifier before attempting to clean your SX25 in the manner described below.</p> <p>Never apply liquid directly to the SX25.</p> <p>Never use abrasives.</p> <p>Never rub in a circular motion.</p>
Cover	<p>The cover features a durable high quality powder coat finish. To remove finger marks and dirt, lightly rub the surface with a soft cloth.</p> <p>If the dirt is not removed, dip your cloth in a mild solution of soap and water, squeeze excess moisture from it and then gently reapply to the surface.</p> <p>Stubborn dirt may be removed by the application of a small quantity of isopropyl alcohol, applied directly to the cleaning cloth only, and reworking the effected area.</p>
Front Panel	<p>The SX25 front panel features a high quality electroplate finish. Over time the surface may retain finger marks and may need to be cleaned to restore it to original condition.</p> <p>Regular Cleaning</p> <p>Gently wipe the front panel with a very clean cotton cloth. Wipe across the surface and never in a circular motion.</p> <p>Removing Stubborn Marks</p> <p>Only attempt this infrequently, as too regular or vigorous application may damage the surface.</p> <p>Apply a small quantity of any car polish containing carnauba wax to a very clean cotton cloth.</p>
Note:	<p>The car polish must state "Safe for Clear Coats" as the polish will therefore contain the absolute minimum amount of abrasive compound.</p> <p>Gently wipe over the front panel in lateral motion, allow to dry then gently wipe off with a very clean cotton cloth.</p>



8

Warranty Information

1 Year Limited Warranty

The Perreaux SX25 is warranted free from defects in material and workmanship under normal use for a period of 1-year (365 days) from the date of purchase.

To extend the warranty of the Perreaux SX25 to three (3) years from date of purchase, please return a fully completed warranty registration form along with a copy of the original receipt of purchase to:

Perreaux Industries Ltd
PO Box 305
Mosgiel
Dunedin 9053
New Zealand

For the Extended Warranty Registration Form, please refer to Chapter 9.

3 Year Extended Warranty

The extended warranty for the Perreaux SX25 is three (3) years from the date of purchase. If during the warranty period the SX25 exhibits defects in materials and/or workmanship, it will be repaired or replaced, at our option, without charge for either parts or labour, at our factory in New Zealand. The warranty does not apply to any unit that has been misused, abused or altered.

Any unit that is not performing satisfactorily may be returned to the factory in New Zealand for evaluation. Return authorisation must first be obtained by either calling or writing to Perreaux prior to shipping the unit. Perreaux Industries Ltd and its authorised distributors and dealers shall not be held liable for any freight or insurance charges. Freight and insurance charges to and from the Perreaux factory will be the sole responsibility of the owner of the unit.

There is no other express warranty on the SX25. Neither this warranty nor any other warranty, express or implied, including any implied warranties of merchantability of fitness, shall extend beyond the warranty period. No responsibility is assumed for any incidental or consequential damages.

Obtaining Service

In the event that you are experiencing difficulty with your SX25, please as a first step consult the troubleshooting guide in Chapter 10. For further assistance, please contact your Perreaux dealer.



9

Extended Warranty Registration Form

Please complete this form and either fax, mail or e-mail it, along with a copy of the original receipt, to Perreaux Industries Ltd.

Fax: +64 3 489 2976

Mail: Perreaux Industries Ltd
PO Box 305
Mosgiel
Dunedin 9053
New Zealand

E-mail: nz.info@perreaux.com

Alternatively, complete the online Warranty Registration Form on our website – www.perreaux.com.



3 Year Extended Warranty Form



Name:

Address:

Suburb:

City:

Country:

Telephone:

E-mail:

Website:

Product:

Serial No:

Dealer:

Purchase Date: / /
d d m m y y y y

There is no output from my system

Please use this guide if you are experiencing any problems with the SX25 in your system. It will provide possible solutions for some given symptoms.

SX25 not turned on

Make sure the SX25 power switch is in the DOWN position.

AC cord not plugged in

Check that the AC cord is plugged into the IEC socket on the rear of the SX25.

Mains power not turned on

Check if the power is turned on at the mains socket on the wall.

Interconnect cables not connected

Make sure that the input and output interconnect cables are plugged in and are connected to the respective RCA sockets on the rear of the SX25.

Source not turned on

Check that your source component is plugged in to the mains and the power is turned on.

Source not set to play

Ensure that your source component is playing the recording you would like to listen to, and that pause is not pressed.

No volume setting

Make sure that the volume on your preamplifier is set to a suitable level.

Preamplifier set to incorrect input

Confirm that the input on your preamplifier is connected to the appropriate source output.

Loud speakers not connected

Check that your loud speakers are firmly connected via cables into the binding posts on the rear of the SX25.



I can hear a hum coming through my loud speakers

Input sockets and/or output binding posts corroded
Check that the input and output RCA sockets and binding posts on the rear of the SX25 are free from corrosion.

Interconnect cables damaged
Make sure that the integrity of your interconnect cables is sound and they are firmly connected to your source and the SX25.

SX25 is close to external interference
Check the proximity of your SX25 to any possible source of EMI and/or RF interference, for example computers, televisions, amplifiers, speakers, etc. Ideally the SX25 should be placed as close as possible to your source.



The correlation between published specifications and sonic quality can be unreliable. A list of numbers reveals virtually nothing. All technical measurements must be subject to qualitative as well as quantitative interpretation. Measurements of the SX25 reveal excellent results by any standards. Tested at 115V and 230V after a 10 minute warm up period.

**Specifications
in Brief**

Rated Power Output (<i>per channel</i>).....	25W _{RMS} into 8Ω
.....	35W _{RMS} into 4Ω
Voltage Swing.....	55.2V _{p-p}
Input Sensitivity.....	0.63V _{RMS}
Gain.....	27.1dB
Input Impedance:	
Typically.....	40kΩ
Total Harmonic Distortion (<i>THD+N</i>):	
Typically.....	0.002%, @ 1kHz into 8Ω
20Hz to 20kHz.....	<0.02%
Frequency Response:	
20Hz–20kHz.....	+0dB, -0.25dB
5Hz–60kHz.....	+0dB, -1.0dB
Signal to Noise Ratio:	
Rated Output (<i>unweighted</i>).....	100dB
Dynamic Headroom (<i>rated with music</i>).....	>2.0dB
Power Consumption:	
Idle.....	10W
Maximum (<i>at 35W per channel into 4Ω</i>).....	80W

Audio Connections

Inputs.....	1 pair line level (<i>RCA</i>)
Outputs.....	1 pair line level (<i>RCA</i>)
.....	2 pairs speaker binding posts

Other Connections

IEC AC mains input receptacle

Mains Input Voltage

115V or 230V AC at 50Hz/60Hz
(*Set within the SX25 at time of manufacture*)



Internal Mains Fuse Rating

1 x 2SB 1A slow blow
(NOT user serviceable)

Internal Output Fuse Rating

2 x 2SB 4A normal blow
(NOT user serviceable)

Overall Dimensions

Width.....216mm (8.5")
Depth.....178mm (7.0")
Height..... 58mm (2.3")

Weight

Gross3.0kg (6.6lb)
Net..... 2.4kg (5.3lb)

Specifications Explained

Rated Power Output (*per channel*).....25W_{RMS} into 8Ω

This is the optimum operating level of the unit, offering the best performance whilst allowing a large enough buffer to accommodate the unpredictable nature of music. It is the reference output level to which other specifications, such as sensitivity and gain, are referred. The Rated Output does not indicate the full capability of the SX25.

Voltage Swing 55.2V_{p-p}

Loud transients call for a sudden burst of power from the amplifier to drive the speakers. This force is voltage. Peak-to-peak voltage is a more useful specification than Watts when it comes to delivering power to a speaker.

Input Sensitivity0.63V_{RMS}

The Input Sensitivity figure indicates the input voltage required to achieve “rated” output (25W_{RMS} into 8Ω).

Gain 27.1dB

The amount of amplification the amplifier is asserting on the input signal. Gain can be calculated by dividing the rated output by the input sensitivity.

Input Impedance..... 40kΩ

The resistance “load” that is presented to the source component that is driving the SX25.



THD+N0.002%, @ 1kHz into 8Ω

Total Harmonic Distortion + Noise is the percentage of output signal which is made up of frequencies added due to harmonics of the fundamental frequency and noise. By using low-noise input circuitry and Class A signal stages, Perreux engineers have kept this figure to a minimum.

Frequency Response.....20Hz to 20kHz, +0dB -0.25dB

Describes the frequency range where the amplitude or strength of the output signal deviates by no more than 0.25dB.

Signal to Noise Ratio (*unweighted*)..... 100dB

The ratio of desired signal to noise signals in the output. Perreux engineers have designed the SX25 to maintain a low noise floor.

Dynamic Headroom >2.0dB

This indicates the SX25 can provide more than enough extra power to cope with the sharpest musical transients. Without adequate headroom, an amplifier can become unstable under clipping conditions. Perreux amplifiers are intrinsically stable under all dynamic conditions.

12

Physical Dimensions

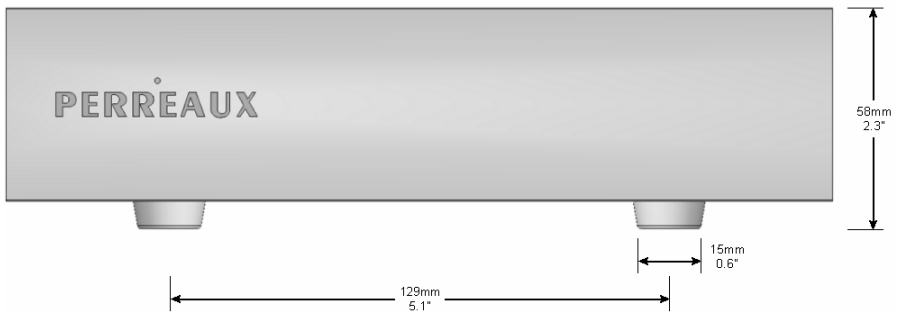
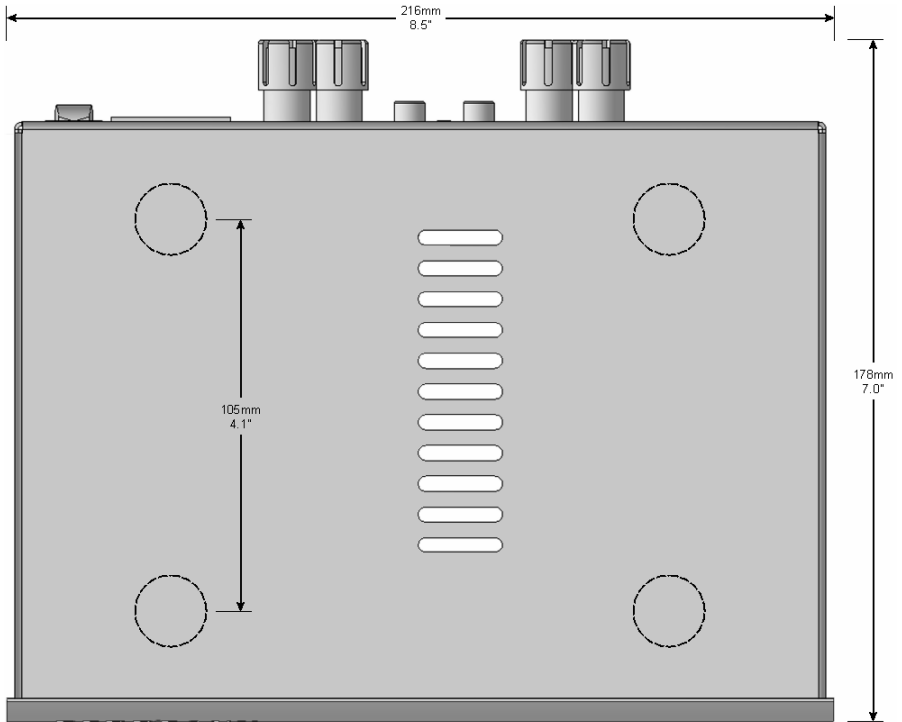



For more information please contact your Perreaux dealer, or contact:

Perreaux Industries Ltd
PO Box 305
Mosgiel
Dunedin 9053
New Zealand

Ph: +64 3 489 2975

Fax: +64 3 489 2976

E-mail: nz.info@perreaux.com

Internet: www.perreaux.com



Installation Notes

A series of horizontal lines for writing installation notes, starting from a vertical line on the left and extending across the page.